

Network calculus : Min-plus system theory applied to communication networks

Jean-Yves Le Boudec and Patrick Thiran
LCA-ISC, School of Computer and
Communication Sciences
EPFL

CH-1015 Lausanne
Patrick.Thiran@epfl.ch
<http://icawww.epfl.ch>

2

Contents

1. What is Network Calculus ?
"Network calculus", J-Y Le Boudec and P. Thiran,
Lecture Notes in Computer Sciences vol. 2050,
Springer Verlag, also available on-line at
<http://icawww.epfl.ch>
2. Preliminaries:
 - Arrival and service curves
 - Backlog, delay bounds
3. A new system theory: min-plus
4. Min-plus algebra in action:
 - Greedy shaper
 - Window flow control
 - Video smoothing

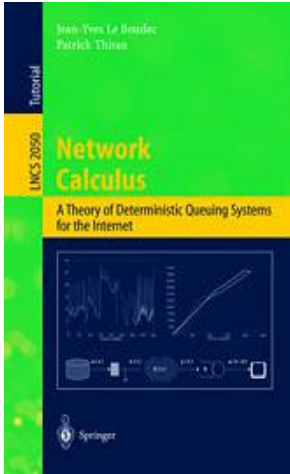

1. What is Network Calculus ?

3

- Deterministic analysis of queuing / flow systems arising in communication networks
- A Min-Plus or Max-Plus algebra filtering theory

The standard Linear Theory

4

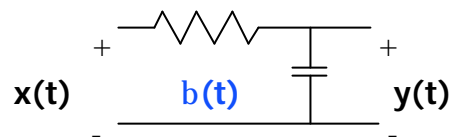

- A LTI filter in conventional algebra $(\mathbb{R}, +, \times)$
 - Input signal = electrical voltage $x(t)$
 - System = circuit (filter) with impulse response $\mathbf{b}(t)$
 - Output = convolution of $x(t)$ and $\mathbf{b}(t)$:

$$y(t) = \int_0^t \mathbf{b}(t-s) x(s) ds$$

5

Network Calculus uses Min-Plus Linear Theory

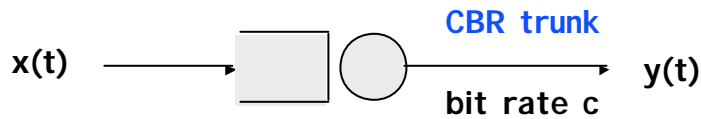

- A linear system in min-plus algebra $(\mathbb{R}, \min, +)$
- Input = arrived traffic in $[0, t]$, $x(t)$
 - System = CBR trunk of rate c : $\mathbf{b}(t) = ct$
 - Output = convolution of $x(t)$ and $\mathbf{b}(t)$:

$$y(t) = \inf_s \{ \mathbf{b}(t-s) + x(s) \}$$

6

Network Calculus uses Max-Plus Linear Theory

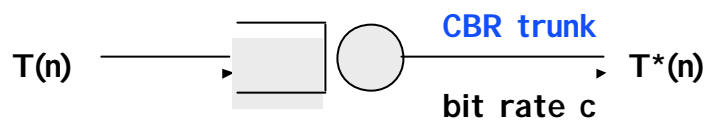

- A linear system in max-plus algebra $(\mathbb{R}, \max, +)$
- Input = arrival time of n th packet (cell): $T(n)$
 - System = CBR trunk of rate c : $\mathbf{b}^{-1}(n) = 424n/c$
 - Output time = convolution of $T(n)$ and $\mathbf{b}(n)$:

$$T^*(n) = \max_m \{ \mathbf{b}^{-1}(n-m) + T(m) \}$$

2. Preliminary Concepts Arrival and Service Curves

- Internet integrated services use the concepts of *arrival curve* and *service curves*

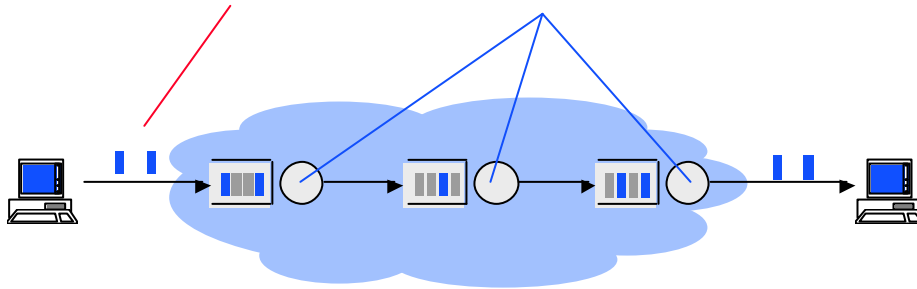

Arrival Curves

- Arrival curve α : For any times $0 \leq s \leq t$, the cumulative flow $x(\cdot)$ satisfies

$$x(t) - x(s) \leq \alpha(t-s)$$

Examples:

- leaky bucket $\alpha(u) = ru + b$
- standard arrival curve in the Internet $\alpha(u) = \min(pu + M, ru + b)$

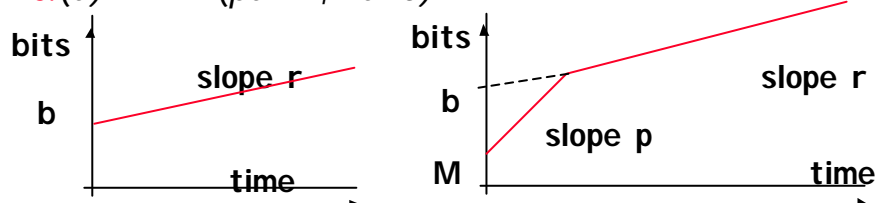

Arrival Curves can be assumed sub-additive

- **Theorem:** α can be replaced by a *sub-additive* function
- sub-additive: $\alpha(s+t) \leq \alpha(s) + \alpha(t)$
- concave \Rightarrow subadditive

Example

- MPEG files, 25 frames/sec

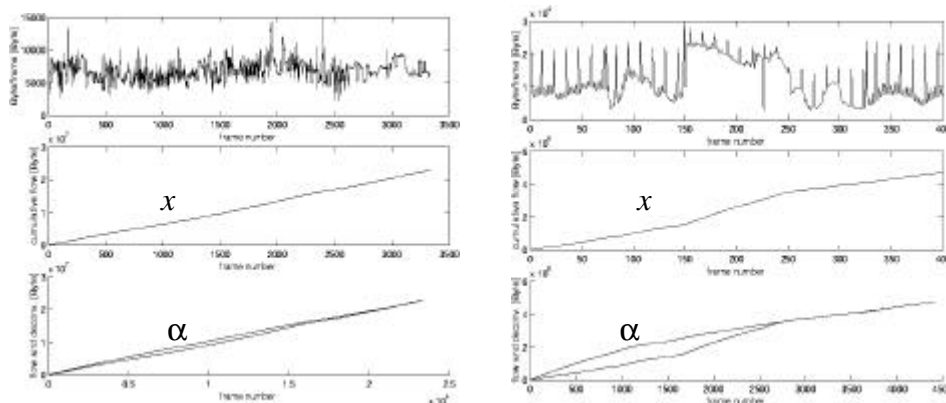

Service Curve

11

□ System S offers a service curve β to a flow iff for all t there exists some s such that

$$y(t) - x(s) \geq b(t-s)$$

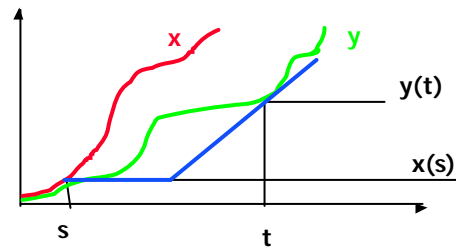
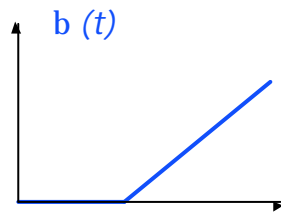

The constant rate server has service curve $b(t)=ct$

12

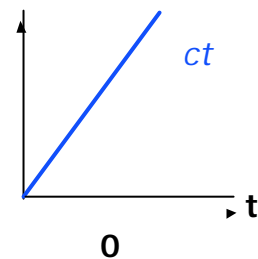
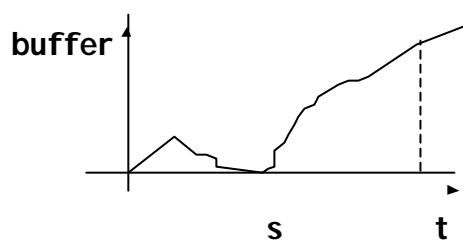

Proof: take s = beginning of busy period:

$$y(t) - y(s) = c(t-s) \text{ and } y(s) = x(s)$$

$$\rightarrow y(t) - x(s) = c(t-s)$$

The guaranteed-delay node has service curve d_T

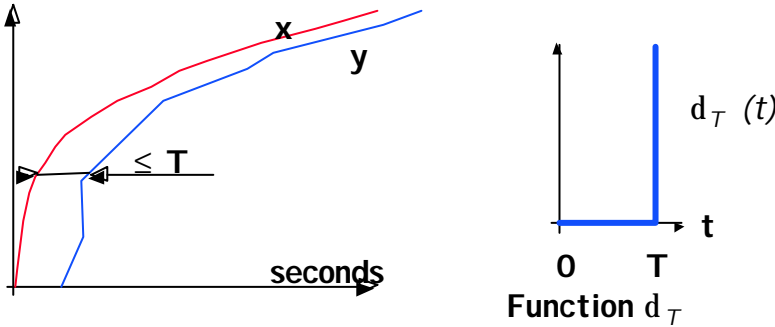

The standard model for an Internet router

□ rate-latency service curve

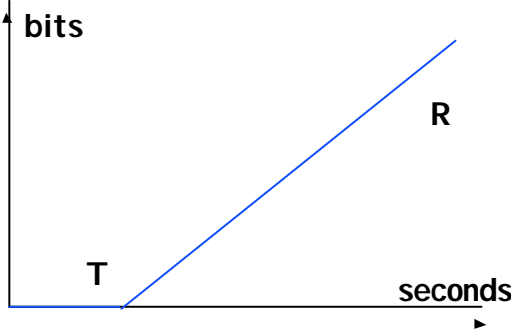

Tight Bounds on delay and backlog

15

If flow has arrival curve α and node offers service curve β then

$$\square \text{backlog} \leq \sup (\alpha(s) - \beta(s))$$

$$\square \text{delay} \leq h(\alpha, \beta)$$

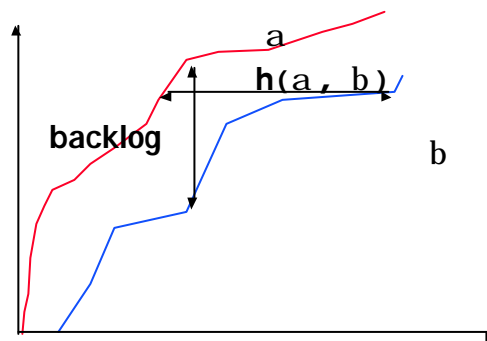

16

3. Another linear system theory: Min-Plus

\square Standard algebra: $\mathbb{R}, +, \times$

$$a \times (b + c) = (a \times b) + (a \times c)$$

\square Min-Plus algebra: $\mathbb{R}, \min, +$

$$a + (b \wedge c) = (a + b) \wedge (a + c)$$

\square Max-Plus algebra: $\mathbb{R}, \max, +$

$$a + (b \vee c) = (a + b) \vee (a + c)$$

Min-plus convolution \otimes

- Standard convolution in $(\mathbb{R}, +, \int)$ (LTI filter)

$$y(t) = (\mathbf{b} * x)(t) = \int \mathbf{b}(t-u) x(u) du$$

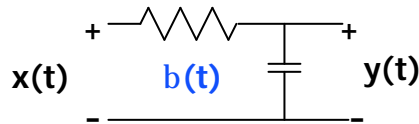

- Min-plus convolution in $(\mathbb{R}, +, \wedge)$ is linear ($\wedge = \min$) (greedy lossless shaper)

$$y(t) = (\mathbf{b} \otimes x)(t) = \inf_u \{ \mathbf{b}(t-u) + x(u) \}$$

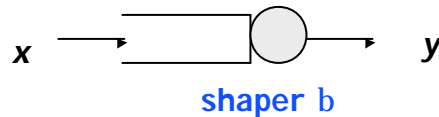

Example

- Min-plus convolution

$$(f \otimes g)(t) = \inf_u \{ f(t-u) + g(u) \}$$

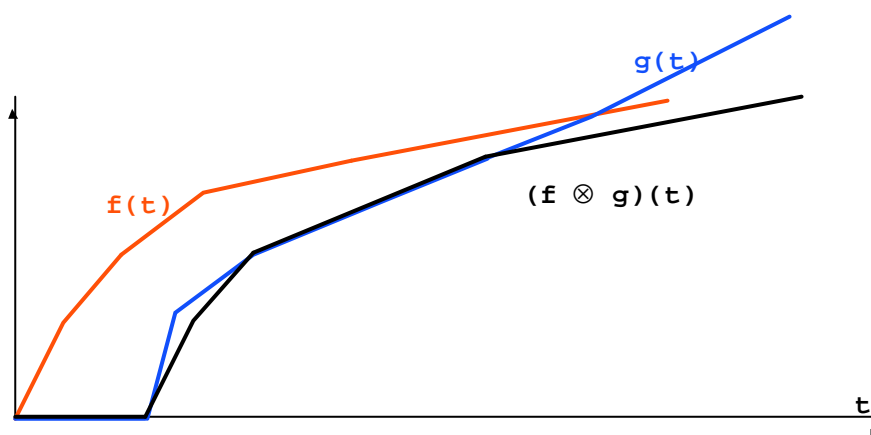

We can express arrival and service curves with min-plus

□ Arrival Curve property means for all $0 \leq s \leq t$,

$$x(t) - x(s) \leq \alpha(t-s)$$

$$\Leftrightarrow x(t) \leq x(s) + \alpha(t-s) \text{ for all } 0 \leq s \leq t$$

$$\Leftrightarrow x(t) \leq \inf_u \{ x(u) + \alpha(t-u) \}$$

$$\Leftrightarrow x \leq x \otimes \alpha$$

□ Service Curve guarantee means there exists some

$$0 \leq s \leq t: y(t) - x(s) \geq \beta(t-s)$$

$$\Leftrightarrow y(t) \geq x(s) + \beta(t-s) \text{ for some } 0 \leq s \leq t$$

$$\Leftrightarrow y(t) \geq \inf_u \{ x(u) + \beta(t-u) \}$$

$$\Leftrightarrow y \geq x \otimes \beta$$

The composition theorem

□ **Theorem:** the concatenation of two network elements each offering service curve β_i offers the service curve $\beta_1 \otimes \beta_2$

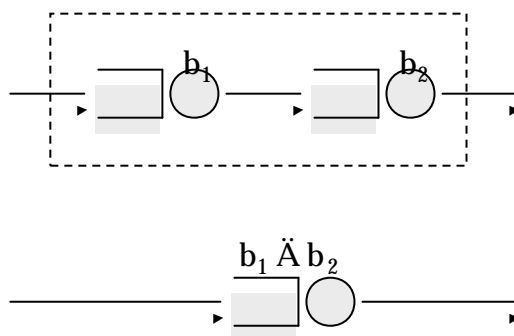

Example

□ tandem of routers

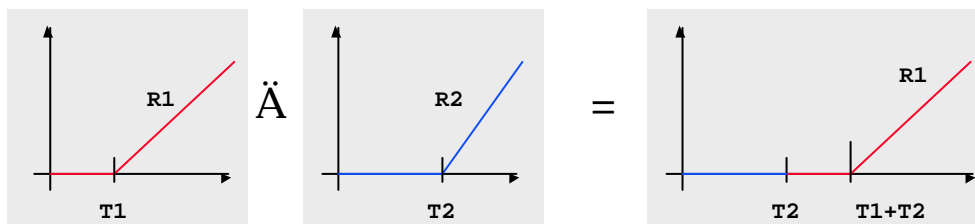
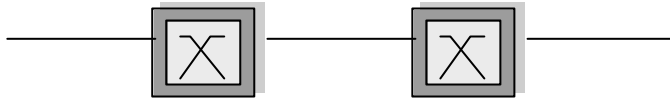

Pay Bursts Only Once

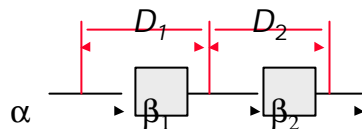

$$D_1 + D_2 \leq (2b + RT_1) / R + T_1 + T_2$$

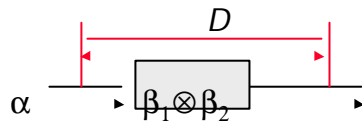

$$D \leq b / R + T_1 + T_2$$

end to end delay bound is less

4. Min-plus System Theory in Action 23

□ **Classical system theory in action:** the problem

$$x(0) = x_0$$

$$dx/dt(t) = \Pi(x)(t)$$

has one solution for most operators Π (Lipschitz)

□ **Min-plus system theory in action:** does the problem

$$x(t) \leq a(t)$$

$$x(t) \leq \Pi(x)(t)$$

have one maximum solution? For which operators Π ?

Min-Plus Operators $P(x)(t)$ 24

□ $x(t), y(t)$ are non negative, wide-s increasing funct. of t

□ Π is **isotone** if $x(t) \leq y(t) \rightarrow \Pi(x)(t) \leq \Pi(y)(t)$

□ Π is **upper-semi continuous** if $\inf_i(\Pi(x_i)) = \Pi(\inf_i(x_i))$

It implies that $\Pi(x \wedge y) = \Pi(x) \wedge \Pi(y)$ ($\wedge = \min$)

□ Π is **min-plus linear** if

Π is upper-semi continuous and

for any constant K , $\Pi(x + K) = \Pi(x) + K$

Examples of operators: Min-plus convolution $\dot{\Delta}$ and deconvolution \emptyset

- Min-plus convolution in $(\mathbb{R}, +, \wedge)$ is linear
 $\Pi(x)(t) = (x \otimes \beta)(t) = \inf_u \{ x(t-u) + \beta(u) \}$
- Min-plus deconvolution in $(\mathbb{R}, +, \wedge)$ is non linear
 $\Pi(x)(t) = (x \emptyset \beta)(t) = \sup_u \{ x(t+u) - \beta(u) \}$
- Property of \emptyset :
 $x(t) \leq (y \dot{\Delta} \beta)(t) \Leftrightarrow (x \emptyset \beta)(t) \leq y(t)$

Min-Plus System Theory in Action

- From Baccelli et al, "Synchronization and Linearity";
 assume that Π is isotone and upper-semi-continuous.
Theorem :
 the problem
 $x(t) \leq a(t) \wedge \Pi(x)(t)$
 has one maximum solution, given by $x(t) = \underline{\Pi}(a)(t)$
- (Definition of closure)
 $\underline{\Pi}(x) = \inf \{ x, \Pi(x), \Pi \circ \Pi(x), \Pi \circ \Pi \circ \Pi(x), \dots \}$
- An easy case: convolution by a subadditive curve σ :
 (Remember σ subadditive $\Leftrightarrow \sigma(t+s) \leq \sigma(t) + \sigma(s)$)
 $\underline{\Pi}(x) = \underline{(x \otimes \sigma)} = (x \otimes \underline{\sigma}) = (x \otimes \sigma) = \Pi(x)$

Example 1. Linear Characterization of Shapers

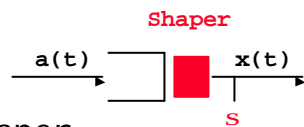

Definition: shaper

- forces output to be constrained by σ

$$x(t) - x(s) \leq \sigma(t - s)$$

- stores data in a buffer if needed

- Hence the shaper maximises $x(t)$ such that

$$x(t) \leq a(t)$$

$$x(t) \leq (x \dot{\wedge} \sigma)(t)$$

Modelling and solving Example 1

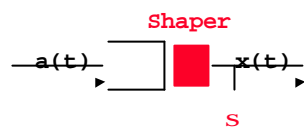

- Therefore look for the maximal solution of

$$x(t) \leq a(t) \dot{\wedge} (x \dot{\wedge} \sigma)(t) \quad [\wedge = \min]$$

which is

$$x(t) = (\underline{\sigma} \dot{\wedge} a)(t)$$

and, if σ is sub-additive,

$$x(t) = (\sigma \dot{\wedge} a)(t)$$

Example 2. Window flow controller

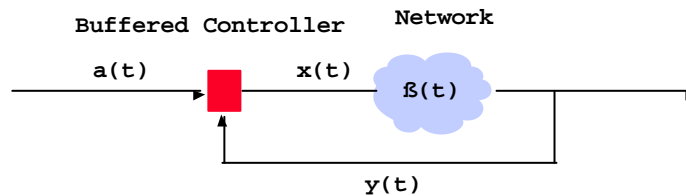

- Chang 96, Agrawal and Rajan 96
- Network offers a service curve \mathbf{b} to flow $x(t)$,
- Controller forces output $x(t)$ so that backlog in network $\leq W$ (fixed window size)
- What service curve does the complete system offer ?

Modelling Example 2

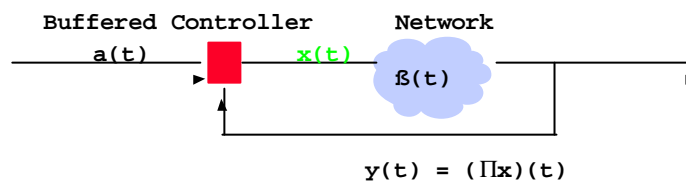

- the controller maximises $x(t)$ such that
 - $x(t) \leq a(t)$
 - $x(t) \leq y(t) + W = \mathbf{P}(x)(t) + W$
- output $y(t) = \mathbf{P}(x)(t)$ is not known but
 - $y(t) \geq (x \dot{\mathbf{A}} \mathbf{b})(t)$

Solving Example 2

- Maximal solution of $x(t) \leq a(t) \wedge \{P(x)(t) + W\}$ is

$$x(t) = (\underline{\Pi+W})(a)(t)$$
- Output $y(t) = P(x)(t)$ is not known but $y(t) \geq (x \ddot{\Delta} \beta)(t)$
- Hence $(\underline{\Pi+W})(x) = \underline{\Pi}(x) + W \geq (x \ddot{\Delta} \beta) + W = x \ddot{\Delta} (\beta + W)$
- Property: if $\underline{\Pi} \geq \underline{\Pi}'$ and both are isotone then $\underline{\Pi} \geq \underline{\Pi}'$
- Thus $(\underline{\Pi+W})(x) \geq x \ddot{\Delta} (\underline{b+W})$
- In other words:

$$x \geq a \ddot{\Delta} (\underline{b+W})$$
- and

$$y \geq a \ddot{\Delta} \beta \ddot{\Delta} (\underline{\beta+W})$$
- (Chang) this proves that a service curve is $\beta \otimes (\underline{\beta+W})$

Service Curve Property for Example 2

- Example: $\beta(t) = R(t-T)^+$ and $W < RT$:

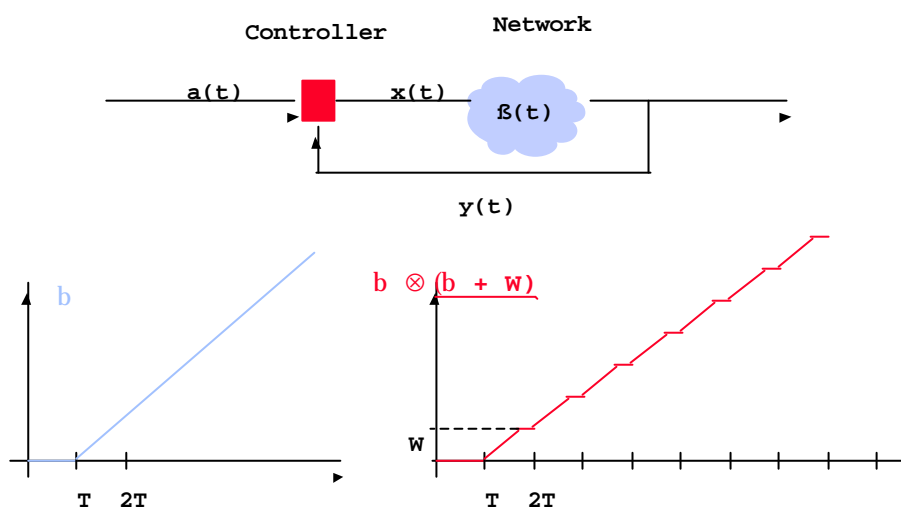

Example 3. Optimal smoother

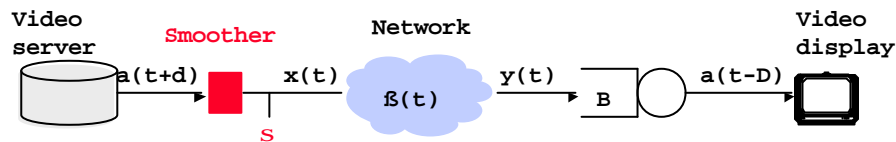

- Le Boudec, Verscheure 2000, Thiran, Le Boudec and Worm, Infocom 2001
- Network offers a service curve \mathbf{b} to flow $x(t)$
- Smoother delivers a flow $x(t)$ conforming to an arrival curve \mathbf{s} .
Can look-ahead on the server (max d time units)
- Video stream is stored in the client buffer B and read after a playback delay D .
- Which smoothing strategy does minimize D and B ?
- Is look-ahead useful ?

Modelling Example 3

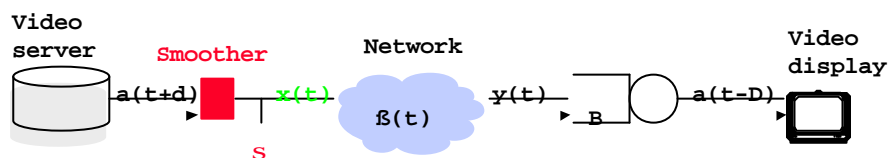

- Smoothed flow $x(t)$ such that
 - $x(t) \leq \mathbf{d}_0(t)$ (i.e, $x(t) = 0$ if $t \leq 0$)
 - $x(t) \leq a(t+d)$ (look-ahead up to d time units)
 - $x(t) \leq (\mathbf{x} \mathbf{\ddot{A}} \mathbf{s})(t)$ (smoothing)
- Output flow $y(t)$ such that
 - $y(t) \geq a(t-D)$ (no buffer underflow)
 - $y(t) \leq a(t-D) + B$ (no buffer overflow)
- $y(t) = \mathbf{P}(x)(t)$ is not known but $(\mathbf{x} \mathbf{\ddot{A}} \mathbf{b})(t) \leq y(t) \leq x(t)$

Modelling Example 3 (cnt'd)

- Output flow $y(t)$ such that
 - $(x \dot{\wedge} \mathbf{b})(t) \geq a(t-D)$ (no buffer underflow)
 - $x(t) \leq a(t-D) + B$ (no buffer overflow)
 or equivalently using deconvolution operator \oslash
 - $x(t) \geq (a \oslash \mathbf{b})(t-D) = \sup_u \{ a(t-D+u) - \mathbf{b}(u) \}$
 - $x(t) \leq a(t-D) + B$
- Therefore find smallest D, B s.t. maximal solution of
 - $x(t) \leq \{ \mathbf{d}_0(t) \wedge a(t+d) \wedge (a(t-D) + B) \} \wedge \{ (x \otimes \mathbf{s})(t) \}$
 verifies
 - $x(t) \geq (a \oslash \mathbf{b})(t-D)$

Application to Example 3 (cnt'd)

- Maximal solution of
 - $x(t) \leq \{ \mathbf{d}_0(t) \wedge a(t+d) \wedge (a(t-D) + B) \} \wedge \{ (x \otimes \mathbf{s})(t) \}$
 is, with σ sub-additive,
 - $x(t) = \underline{\mathbf{s} \otimes \{ \mathbf{d}_0(t) \wedge a(t+d) \wedge (a(t-D) + B) \}}$
 - $= \mathbf{s}(t) \wedge \{ (\mathbf{s} \otimes a)(t-D) + B \} \wedge (\mathbf{s} \otimes a)(t+d)$
- Need to check that this solution $x(t) \geq (a \oslash \mathbf{b})(t-D)$
 - $\mathbf{s}(t) \geq (a \oslash \mathbf{b})(t-D)$
 - > $D \geq \inf \{ s \geq 0 : (a \oslash (\mathbf{b} \otimes \mathbf{s}))(-s) \leq 0 \}$
 - $(\mathbf{s} \otimes a)(t-D) + B \geq (a \oslash \mathbf{b})(t-D)$
 - > $B \geq ((a \oslash a) \oslash (\mathbf{b} \otimes \mathbf{s}))(0)$
 - $(\mathbf{s} \otimes a)(t+d) \geq (a \oslash \mathbf{b})(t-D)$
 - > $d \geq \inf \{ s \geq 0 : ((a \oslash a) \oslash (\mathbf{b} \otimes \mathbf{s}))(-s) \leq 0 \} - D$

Bounds for D, B and d

□ In summary, we have shown that

- the set of admissible playback delays D , playback buffer B and look-ahead limit d is

$$D \geq D_{\min} = h(a, \mathbf{b} \otimes \mathbf{s})$$

$$D + d \geq (D+d)_{\min} = h(a \oslash a, \mathbf{b} \otimes \mathbf{s})$$

$$B \geq B_{\min} = v(a \oslash a, \mathbf{b} \otimes \mathbf{s})$$

- in particular, there is a minimum playback delay.
- if D, d, B satisfy the constraints above, a schedule is possible; else, there is no schedule that can guarantee correct operation

The formulae have a simple graphical interpretation

(1) compute $\sigma \otimes \beta$

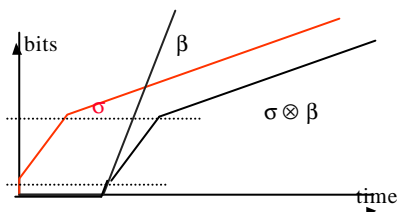

(2) compute the horizontal deviation

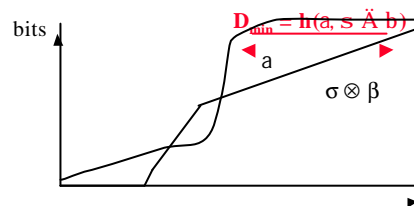

(3) compute $a \oslash a$ and the horizontal deviation

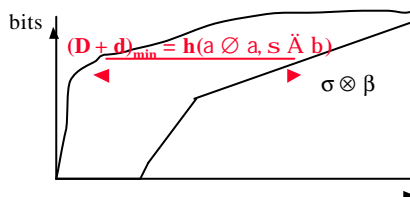

(4) compute the vertical deviation

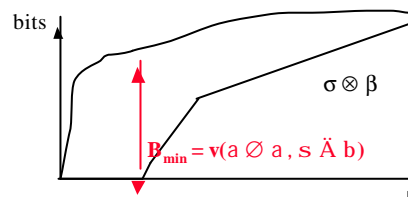

Example: MPEG Trace

- MPEG files, 25 frames/sec, discretized in packets of 416 bytes

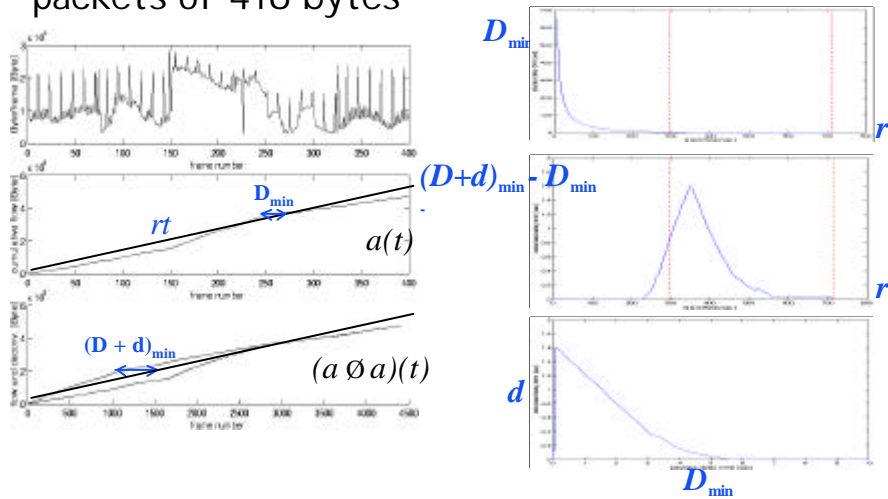

- Actual values of delays depend on the length of the stream and the position of largest burst

- Example: in Jurassic Park trace, largest burst occurs between frames 28000 - 29000

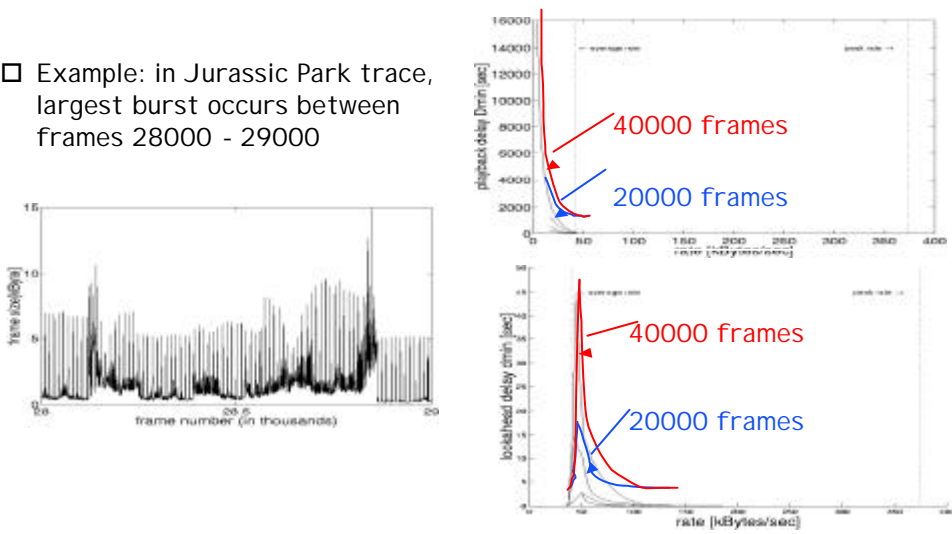

Scheduling for D_{\min} , d_{\min} and B_{\min}

$$x_{\max}(t) = s(t) \wedge (s \otimes a)(t+d_{\min}) \wedge \{ (s \otimes a)(t-D_{\min}) + B_{\min} \}$$

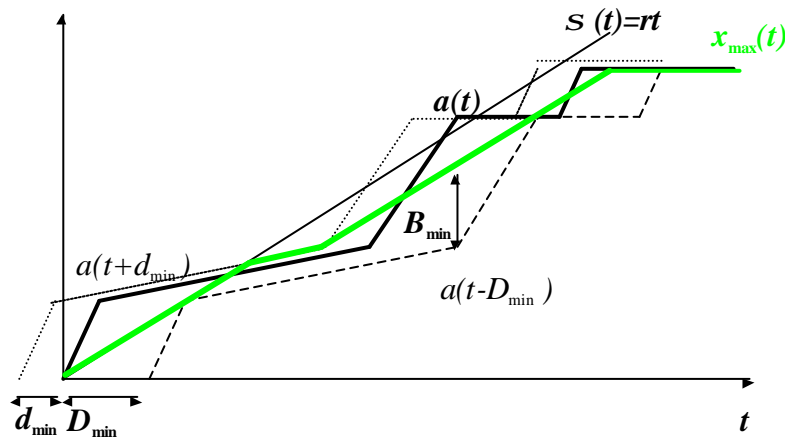

Example 3: Dual problem formulation

- Find smallest D , B and d s.t. the maximal solution of $x(t) \leq d_0(t) \wedge R(t+d) \wedge \{R(t-D) + B\} \wedge (x \ddot{\wedge} s)(t)$ verifies

$$x(t) \geq (R \oslash b)(t-D).$$

- Property of \oslash : $x \leq (x \ddot{\wedge} s) \leftrightarrow (x \oslash s) \leq x$

- Find smallest D , B and d s. t. the minimal solution of $x(t) \geq (R \oslash b)(t-D) \vee (x \oslash s)(t)$ verifies

$$x(t) \leq d_0(t) \wedge R(t+d) \wedge \{R(t-D) + B\}.$$

Max-Plus System Theory in Action

- From Baccelli et al, "Synchronization and Linearity"; assume that Π is isotone and lower-semi-continuous.

Theorem : the problem

$$x(t) \leq a(t) \vee \Pi(x)(t)$$

has one minimum solution, given by $x_{min}(t) = \overline{\Pi}(a)(t)$

- (Definition of super-additive closure)

$$\Pi(x) = \sup \{x, \Pi(x), \Pi \circ \Pi(x), \Pi \circ \Pi \circ \Pi(x), \dots\}$$

- Minimal solution of

$$x(t) \geq (R \oslash b)(t-D) \vee (x \oslash s)(t)$$

is, with σ sub-additive,

$$x_{min}(t) = (R \oslash (b \otimes s))(t-D)$$

Scheduling for D_{min} , d_{min} and B_{min}

$$x_{max}(t) = s(t) \wedge (s \otimes R)(t+d_{min}) \wedge \{(s \otimes R)(t-D_{min}) + B_{min}\}$$

$$x_{min}(t) = (R \oslash (b \otimes s))(t-D) \quad (\text{Le Boudec, Verscheure 2000})$$

+ Other metrics (Feng, Rexford 99):

+ minimal rate variability (Salehi, Zhang, Kurose, Towsley 98)

+ ON/OFF (Zhang, Hui 97)

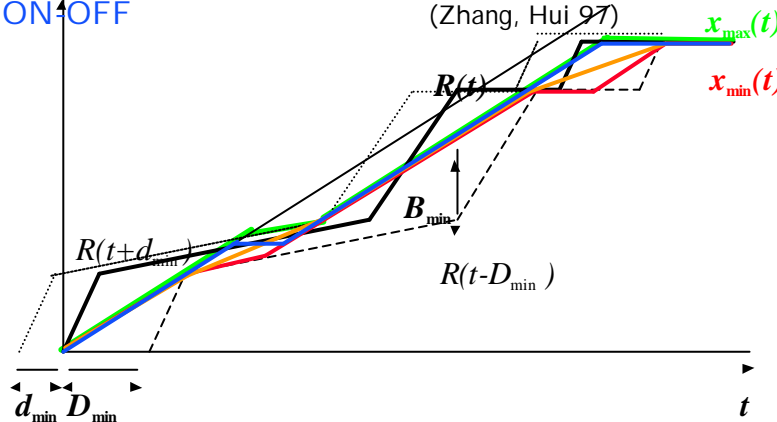

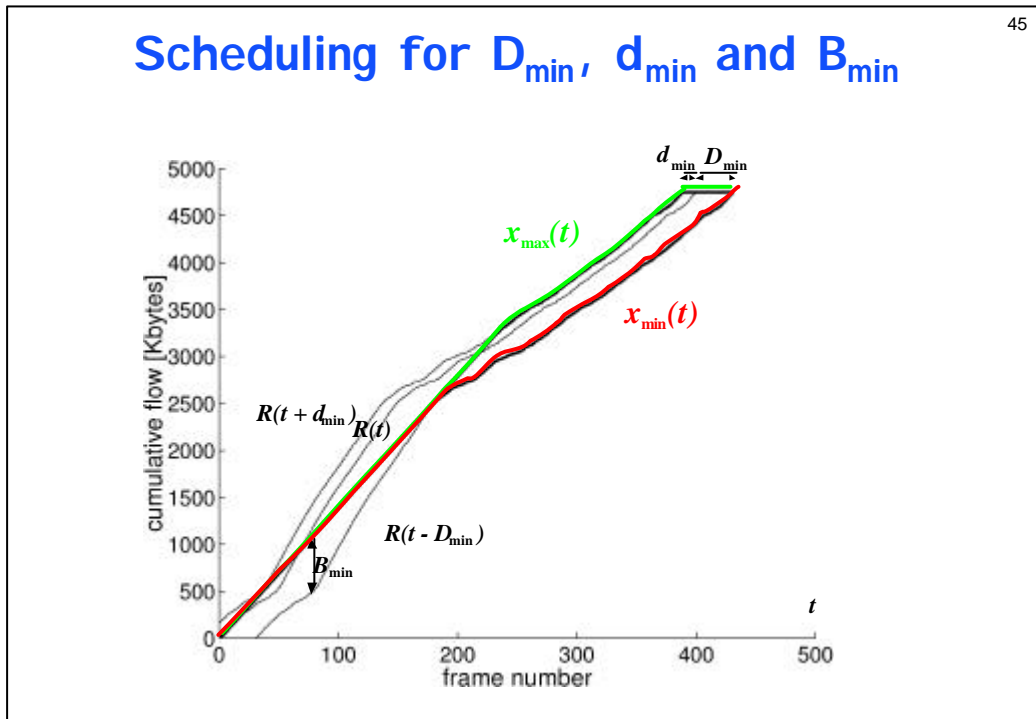

46

Explicit formula for CBR smoothing

- With $s_i(t) = r_i t$ and $b_i(t) = C_i [t - L_i]^+$ ($i = 1, 2, C_i > r_i$)
 If $X \geq L_1 \min(r_1, r_2)$,

$$D_{\min} = L_1 + L_2 + (R \oslash s)(0) / \min(r_1, r_2)$$

$$d_{\min} = L_1 + L_2 + ((R \oslash R) \oslash s)(0) / \min(r_1, r_2) - D$$

$$B_{\min} = ((R \oslash R) \oslash s)(L_2)$$
- With two lossless networks and an intermediate scheduler, instead of one lossless network:

$$D_{\min} (2 \text{ networks}) = D_{\min} (1 \text{ network})$$

$$d_{\min} (2 \text{ networks}) = d_{\min} (1 \text{ network})$$

$$B_{\min} (2 \text{ networks}) \leq B_{\min} (1 \text{ network})$$
- If $L_1 = 0$, then can take $X = 0$ (Rexford, Towsley 1999)
 If $L_1 > 0$, then must take $0 < X \leq L_1 \min(r_1, r_2)$.

Scheduling for D_{min} , d_{min} and B_{min}

$$x_{max}(t) = s(t) \wedge (s \otimes R)(t+d_{min}) \wedge \{(s \otimes R)(t-D_{min}) + B_{min}\}$$

$$x_{min}(t) = (R \oslash (b \otimes s))(t-D)$$
 (Le Boudec, Verscheure 2000)

+ Other metrics (Feng, Rexford 99):

+ minimal rate variability (Salehi, Zhang, Kurose, Towsley 98)

+ ON-OFF (Zhang, Hui 97)

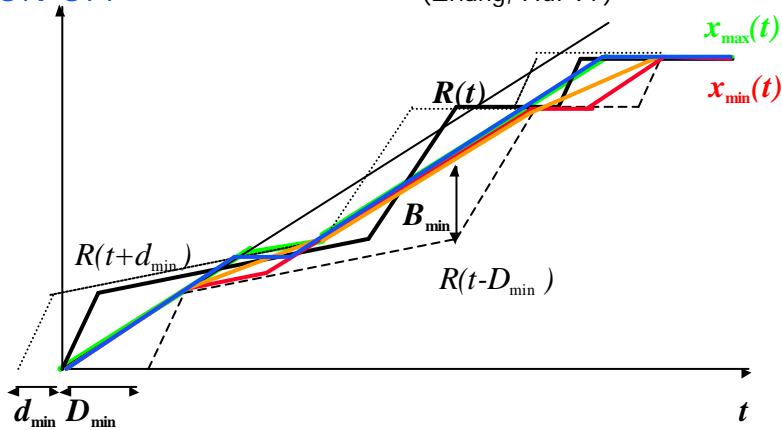

Smoothing problem over 2 networks

□ Same approach for a 2-dimensional system

$$X = (X_1, X_2)$$

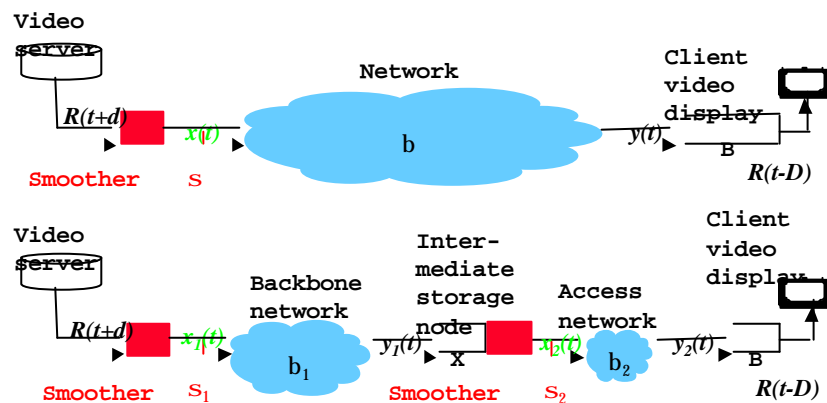

Explicit formula for CBR smoothing

- With $s_i(t) = r_i t$ and $b_i(t) = C_i [t - L_i]^+$ ($i = 1, 2, C_i > r_i$)
 If $X \geq L_1 \min(r_1, r_2)$,

$$D_{min} = L_1 + L_2 + (R \oslash s)(0) / \min(r_1, r_2)$$

$$d_{min} = L_1 + L_2 + ((R \oslash R) \oslash s)(0) / \min(r_1, r_2) - D$$

$$B_{min} = ((R \oslash R) \oslash s)(L_2)$$

- With two lossless networks and an intermediate scheduler, instead of one lossless network:

$$D_{min} (2 \text{ networks}) = D_{min} (1 \text{ network})$$

$$d_{min} (2 \text{ networks}) = d_{min} (1 \text{ network})$$

$$B_{min} (2 \text{ networks}) \leq B_{min} (1 \text{ network})$$

- If $L_1 = 0$, then can take $X = 0$ (Rexford, Towsley 1999)
 If $L_1 > 0$, then must take $0 < X \leq L_1 \min(r_1, r_2)$.

Conclusion

- Network Calculus is a set of tools and theories for the deterministic analysis of communication networks
- A new system theory, which applies min-plus algebra to communication networks
- Does not supersede stochastic queueing analysis, but gives new tools for analysis of sample paths
- "Network calculus", J-Y Le Boudec and P. Thiran, Lecture Notes in Computer Sciences vol. 2050, Springer Verlag, also available on-line at <http://icawww.epfl.ch>